

POSITIONS			
1	25mm Forward	5mm Up	Stock Shift
2	25mm Forward	15mm Up	Stock Shift
3	25mm Forward	25mm Up	Stock or Reverse Shift
4	25mm Forward	35mm Up	Stock or Reverse Shift

(Positions are in relation to stock foot peg position)

BACK SIDE

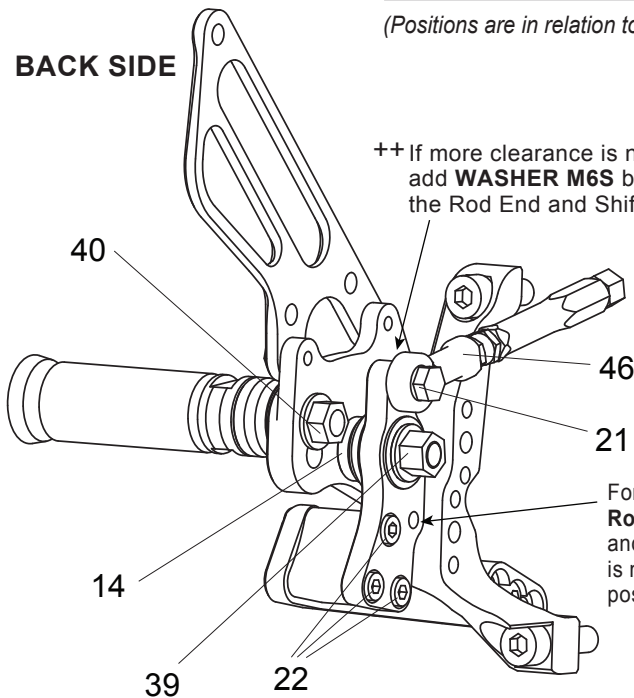

For Reverse Shift, attach Rod End (#46) to lower hole, and make sure Step Plate is mounted at the top position on Base Plate.

1. HEEL GUARD [L] [HG-3L]
3. STEP PLATE [L] [D-1199SP-L]
5. BASE PLATE [L] [D-1299BP-L]
7. SHIFT PEDAL [SPD-1199]
8. SHIFT LINK (BK) [D-V220RS-LINK]
9. SHIFT PEDAL COLLAR (BK) [D-1199RS-SPDCLR]
10. SHIFT ROD 60 M6L-M8 (SV) [SRD-60M6LM8R]
11. NUT M8S [NUT-81199]
14. BEARING COLLAR 5 (BK) [PEGBGCLR-5SB]
15. FOOT PEG [PEG]
16. FOOT PEG END CAP [ST-002]
17. PEDAL TIP (DELRIN) [ST-001D18]
20. FOOT PEG COLLAR 12 [PEGCLR-12]
21. HEX HEAD M6x18mm [HBT-M618]
22. SOCKET HEAD M5x10mm [SBT-M510] x 6
24. SOCKET HEAD M6x15mm [SBT-M615] x 2
27. SOCKET HEAD M8x25mm [SBT-M825]
28. SOCKET HEAD M8x30mm [SBT-M830]
29. BUTTON HEAD M5x10mm [BBT-M510] x 2
30. BUTTON HEAD M6x20mm [SBT-M620]
32. BUTTON HEAD M8x35mm [BBT-M835]
33. REVERSE STUD M6x45mm [STUD-M6L]
34. STUD BOLT M8-45mm [STBT-M845]
37. REVERSE JAM NUT M6 [JNT-6L] x 2
39. FLANGE LOCK NUT M8S [FGLNT-8S]
40. FLANGE NUT M8 [FNT-8]
46. FEMALE REVERSE ROD END M6 [RDED-F6L]

**\* 47. SHIFTER (DUCATI PART)**

++ WASHER M6S (WS-6S) (Not Pictured)