

[L]

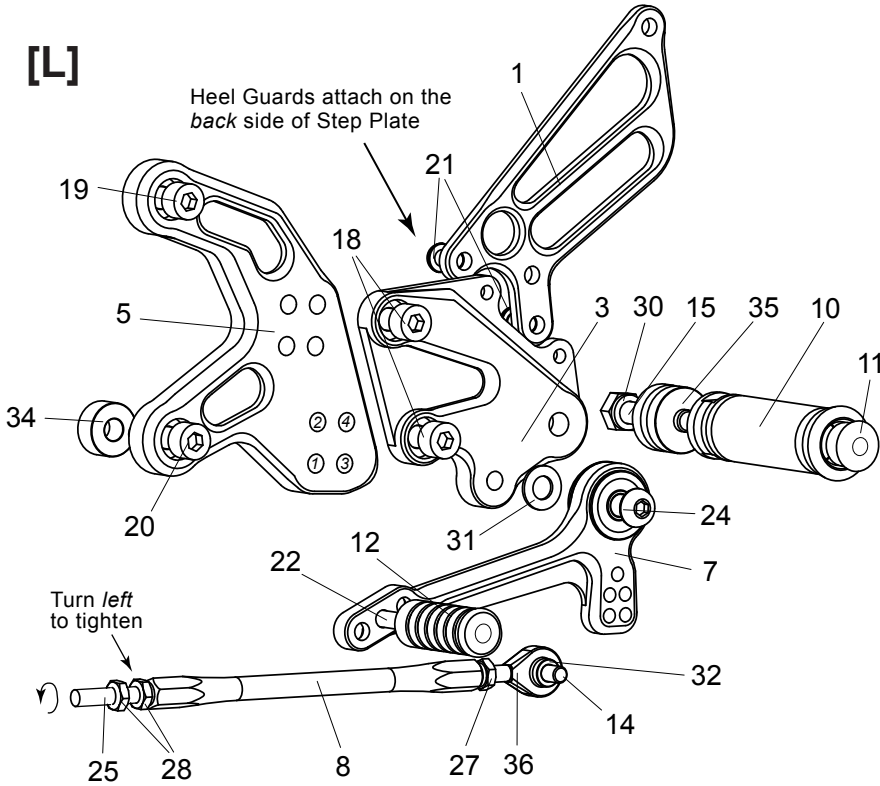

[R]

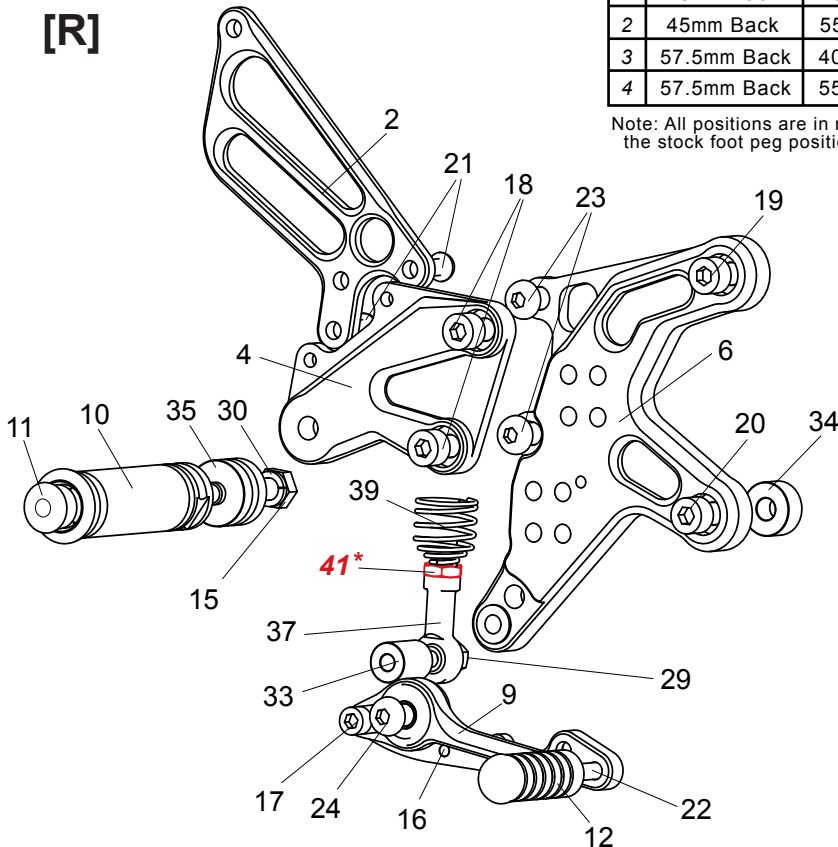

POSITIONS		
1	45mm Back	40mm Up
2	45mm Back	55mm Up
3	57.5mm Back	40mm Up
4	57.5mm Back	55mm Up

Note: All positions are in relation to the stock foot peg position (0mm)

1. (L) HEEL GUARD [HG-6L]
2. (R) HEEL GUARD [HG-6R]
3. (L) STEP PLATE [K-Z917SP-L]
4. (R) STEP PLATE [K-Z917SP-R]
5. (L) BASE PLATE [K-Z9RSBP-L]
6. (R) BASE PLATE [K-Z9RSBP-R]
7. SHIFT PEDAL [SPD-0912]
8. SHIFT ROD 145 (BK) [SRD-145B]
9. BRAKE PEDAL [BPD-SSBP165]
10. FOOT PEG [PEG] x 2
11. FOOT PEG END CAP [ST-002] x 2
12. PEDAL TIP (DELRIN) [ST-001D18] x 2
13. HEX HEAD M5 x 6mm [HBT-M56]
14. HEX HEAD M6 x 20mm [HBT-M620]
15. HEX HEAD M8 x 40mm [HBT-M840] x 2
16. SOCKET HEAD M5 x 35mm [SBT-M535]
17. SOCKET HEAD M6 x 45mm [SBT-M645]
18. SOCKET HEAD M8 x 15mm [SBT-M815] x 4
19. SOCKET HEAD M8 x 20mm [SBT-M820] x 2
20. SOCKET HEAD M8 x 30mm [SBT-M830] x 2
21. BUTTON HEAD M6 x 10mm [BBT-M610] x 4
22. BUTTON HEAD M6 x 20mm [BBT-M620] x 2
23. BUTTON HEAD M8 x 20mm [BBT-M820] x 2
24. BUTTON HEAD M8 x 25mm [BBT-M825] x 2
25. REVERSE STUD M6 x 45mm [STUD-M6L]
26. NUT M5 [NUT-5]
27. JAM NUT M6 [JNT-6]
28. REVERSE JAM NUT M6 [JNT-6L] x 2
29. LOCK NUT M6 [LNT-6]
30. SPLIT WASHER M8 [SWS-8] x 2
31. PEG WASHER M8 [PWS-8]
32. ROD END COLLAR 3 (GD) [RDED-CLR3]
33. ROD END COLLAR 19 (BK) [RDED-CLR19]
34. BASE PLATE COLLAR 9 (BK) [BPCLR-9] x 2
35. PEG COLLAR 15 [PEGCLR-15] x 2
36. MALE ROD END M6 [RDED-M6]
37. FEMALE ROD END 6-M8 [RDED-F6-8]
38. PULL SWITCH STAY 16 [PSTAY-16]
39. RETURN SPRING 40 [RS-RSP]

*40. PULL SWITCH / SPRING (KAWASAKI PART)
 *41. NUT (KAWASAKI PART)

(Back Side)

