

## Buell M2/S3 (L)

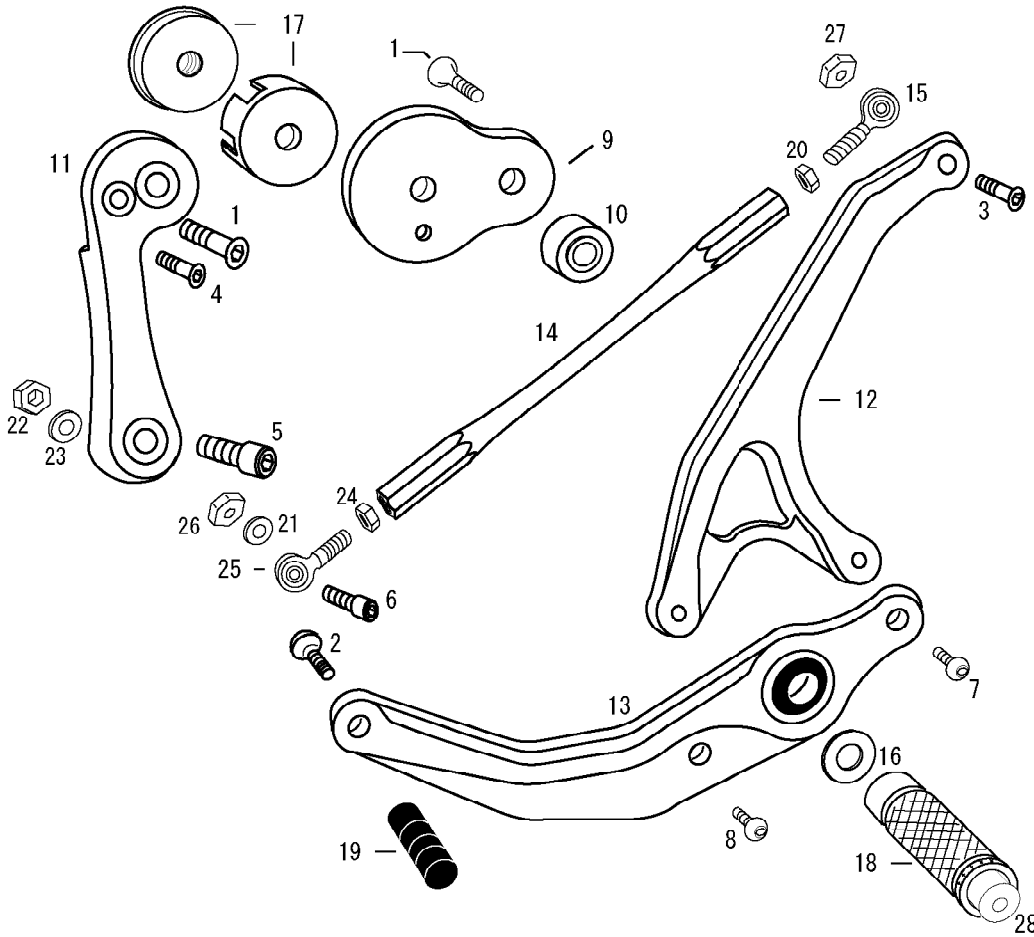

1. FLAT HEAD M8 × 30mm × 2
2. BUTTON HEAD M6 × 25mm
3. BUTTON HEAD M6 × 20mm
4. FLAT HEAD M6 × 10mm
5. SOCKET HEAD M8 × 35mm
6. SOCKET HEAD M6 × 35mm
7. BUTTON HEAD M6 × 15mm
8. BUTTON HEAD M6 × 10mm
9. STEP PLATE [L]
10. FOOT PEG BEARING COLLAR 10
11. BASE PLATE [L]
12. SHIFT ARM
13. SHIFT PEDAL
14. SHIFT ROD 220
15. MALE ROD END M6
16. PEG WASHER M8
17. FRAME MOUNT STAY
18. FOOT PEG
19. PEDAL TIP DELRIN
20. JAM NUT M6
21. WASHER M6
22. NUT M8
23. WASHER M8
24. REVERSE JAM NUT M6
25. MALE REVERSE ROD END M6
26. NUT M6
27. JAM NUT M6
28. FOOT PEG END CAP



## Buell M2/S3 (R)

POSITIONS		
1	50mm Back	50mm Up
2	40mm Back	50mm Up

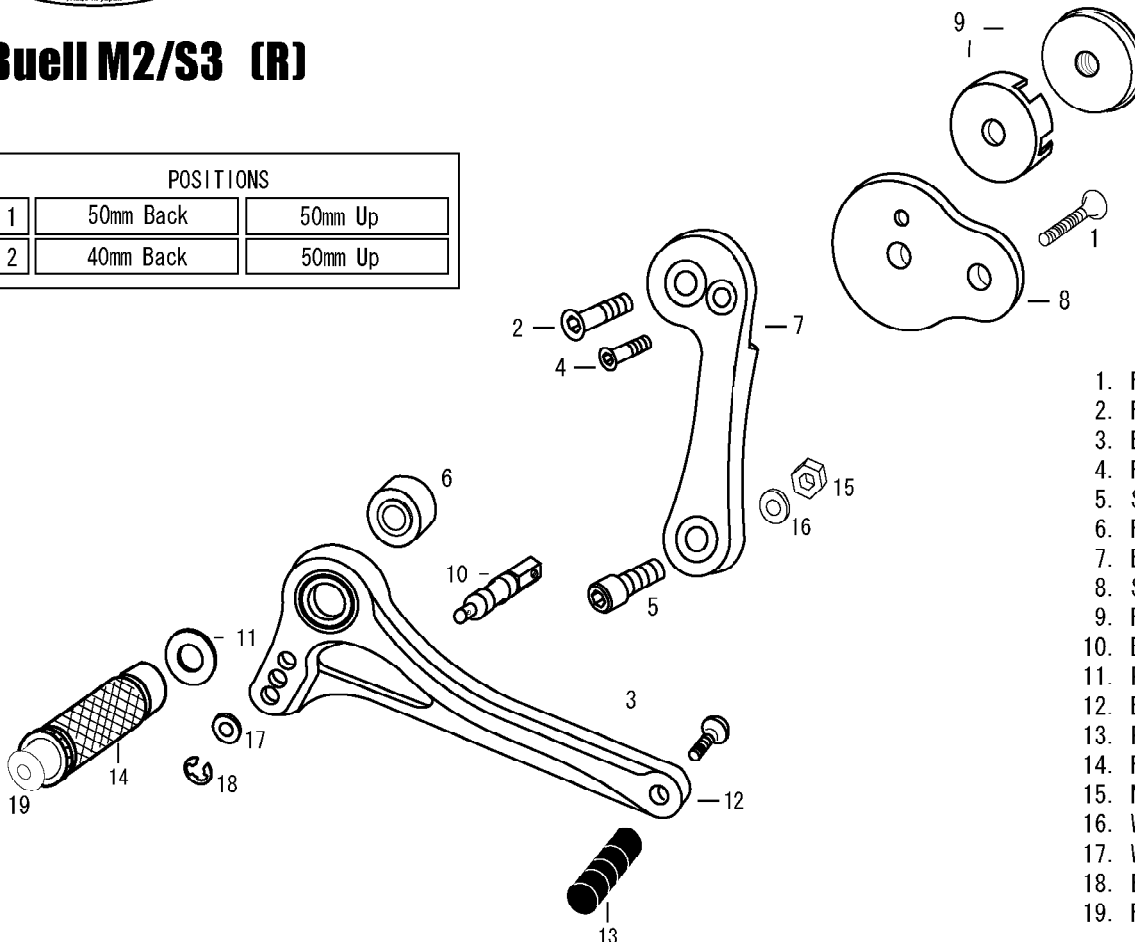

1. FLAT HEAD M8 × 55mm
2. FLAT HEAD M8 × 30mm
3. BUTTON HEAD M6 × 25mm
4. FLAT HEAD M6 × 10mm
5. SOCKET HEAD M8 × 30mm
6. FOOT PEG BEARING COLLAR 10
7. BASE PLATE [R]
8. STEP PLATE [R]
9. FRAME MOUNT STAY
10. BRAKE ROD L80
11. PEG WASHER M8
12. BRAKE PEDAL
13. PEDAL TIP DELRIN
14. FOOT PEG
15. NUT M8
16. WASHER M8
17. WASHER M6
18. E-CLIP M6
19. FOOT PEG END CAP