

ZX-6R '03-'04 [REVERSE PATTERN] (L)

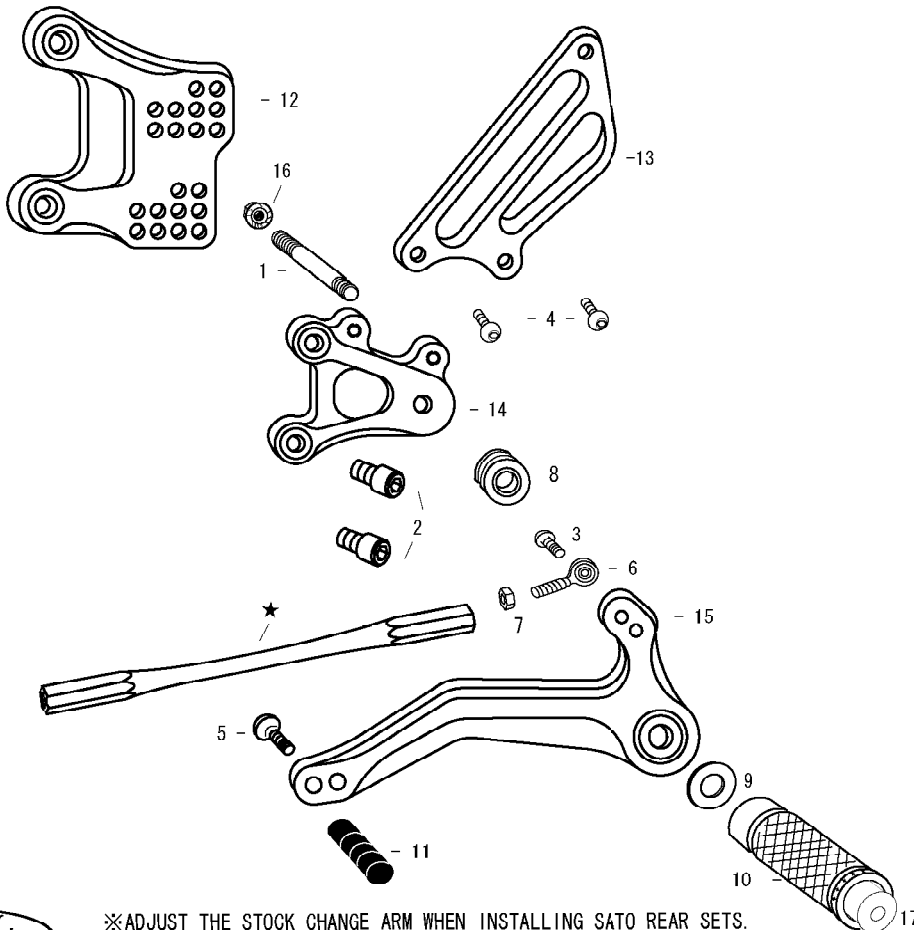

1. STUD BOLT LONG
2. SOCKET HEAD M8×15mm ×2
3. BUTTON HEAD M6×20mm
4. BUTTON HEAD M6×10mm ×2
5. BUTTON HEAD M6×20mm
6. MALE ROD END M6
7. JAM NUT M6
8. FOOT PEG BEARING COLLAR 15
9. PEG WASHER M8
10. FOOT PEG
11. PEDAL TIP DELRIN
12. BASE PLATE [L]
13. HEEL GUARD [L] (HG2)
14. STEP PLATE [L]
15. SHIFT PEDAL (SPD5)
16. FLANGE NUT M8
17. FOOT PEG END CAP

★use stock shift rod



※ADJUST THE STOCK CHANGE ARM WHEN INSTALLING SATO REAR SETS.

ZX-6R '03-'04 (R)

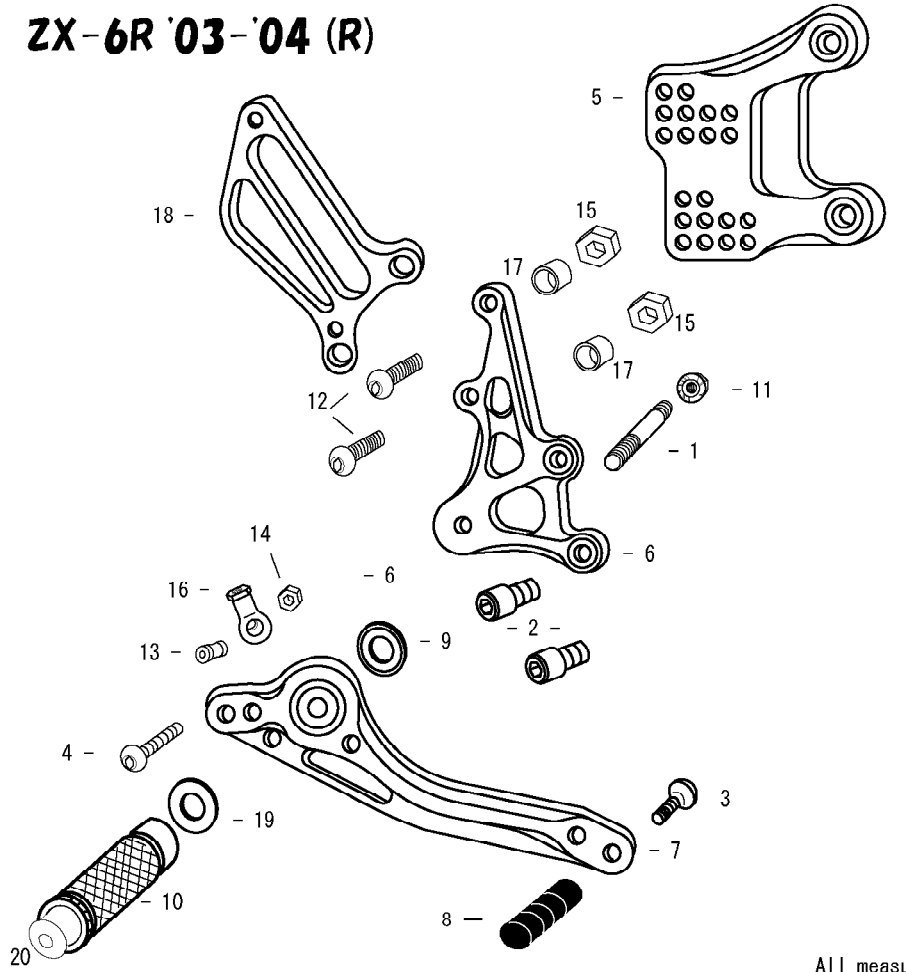

1. STUD BOLT SHORT
2. SOCKET HEAD M8×15mm ×2
3. BUTTON HEAD M6×20mm
4. BUTTON HEAD M6×40mm
5. BASE PLATE [R]
6. STEP PLATE [R]
7. BRAKE PEDAL 150 (BPD1)
8. PEDAL TIP DELRIN
9. BEARING COLLAR SUS
10. FOOT PEG
11. FLANGE NUT M8
12. BUTTON HEAD M8×35mm ×2
13. BRAKE ROD END COLLAR 19 (BK)
14. PLAIN NUT M6
15. PLAIN NUT M8 ×2
16. 6-M8 FEMALE ROD END
17. COLLAR 8 ×2
18. HEEL GUARD [R] (HG9)
19. PEG WASHER M8
20. FOOT PEG END CAP

POSITIONS		
1	10mm Forward	0mm
2	10mm Forward	10mm Up
3	0mm	0mm
4	0mm	10mm Up
5	10mm Back	0mm
6	10mm Back	10mm Up
7	10mm Back	20mm Up
8	20mm Back	0mm
9	20mm Back	10mm Up
10	20mm Back	20mm Up

All measurements are in relation to stock position (0 mm)