

DUCATI M696 (L)

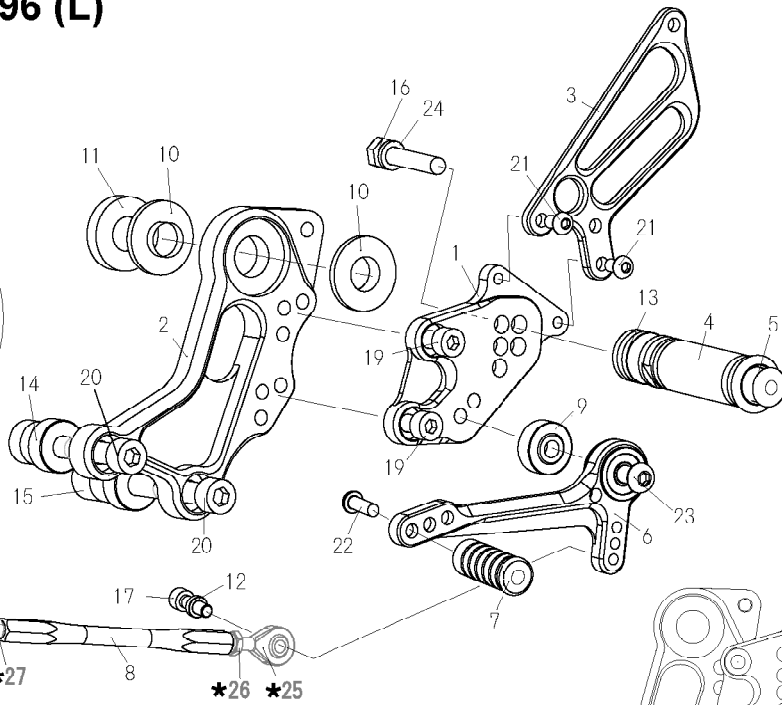

1. STEP PLATE [L]
2. BASE PLATE [L]
3. HEEL GUARD [L] (HG6)
4. FOOT PEG
5. FOOT PEG FND CAP
6. SHIFT PEDAL SCP75 (SPD12)
7. PEDAL TIP
8. SHIFT ROD 130
9. FOOT PEG BEARING COLLAR 10
10. COLLAR 3.5 (BK) × 2
11. COLLAR 7.5 (BK)
12. ROD END COLLAR 3 × 2
13. FOOT PEG COLLAR 12
14. COLLAR 30 (BK)
15. COLLAR 40 (BK)
16. HEX BOLT M8 × 40mm
17. SOCKET HEAD M6 × 20mm
18. SOCKET HEAD M6 × 25mm
19. SOCKET HEAD M8 × 15mm × 2
20. SOCKET HEAD M10 × 65mm (P-1.5) × 2
21. BUTTON HEAD M6 × 10mm × 2
22. BUTTON HEAD M6 × 20mm
23. BUTTON HEAD M8 × 35mm
24. SPLIT WASHER M8
- *25. M6 MALE ROD END (STOCK)
- *26. M6 NUT (STOCK)
- *27. M6 REVERSE NUT (STOCK)
- *28. M6 MALE REVERSE ROD END (STOCK)
- *29. M6 LOCK NUT (STOCK)
- *30. DUCATI CHANGE ARM (STOCK)

Flat side of foot peg bearing collar 10 (#9) should face step plate (#1). With the stepped side facing out toward pedal bearing.

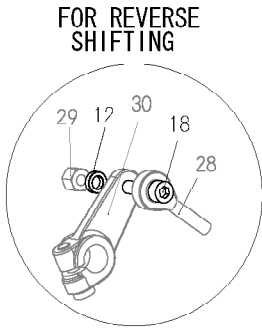

TANDEM BRACKET (Optional)

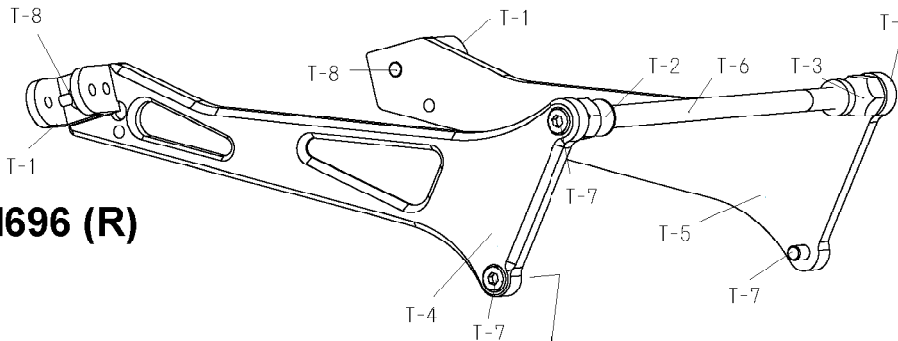

- T-1. TANDEM HOLDER × 2
- T-2. HEX21 L30 M12-M8
- T-3. HEX21 L35 M12-M8
- T-4. TANDEM BRACKET [R]
- T-5. TANDEM BRACKET [L]
- T-6. BOLT M12 × 265mm
- T-7. SOCKET HEAD M8 × 15mm × 4
- T-8. BUTTON HEAD M8 × 15mm × 2

DUCATI M696 (R)

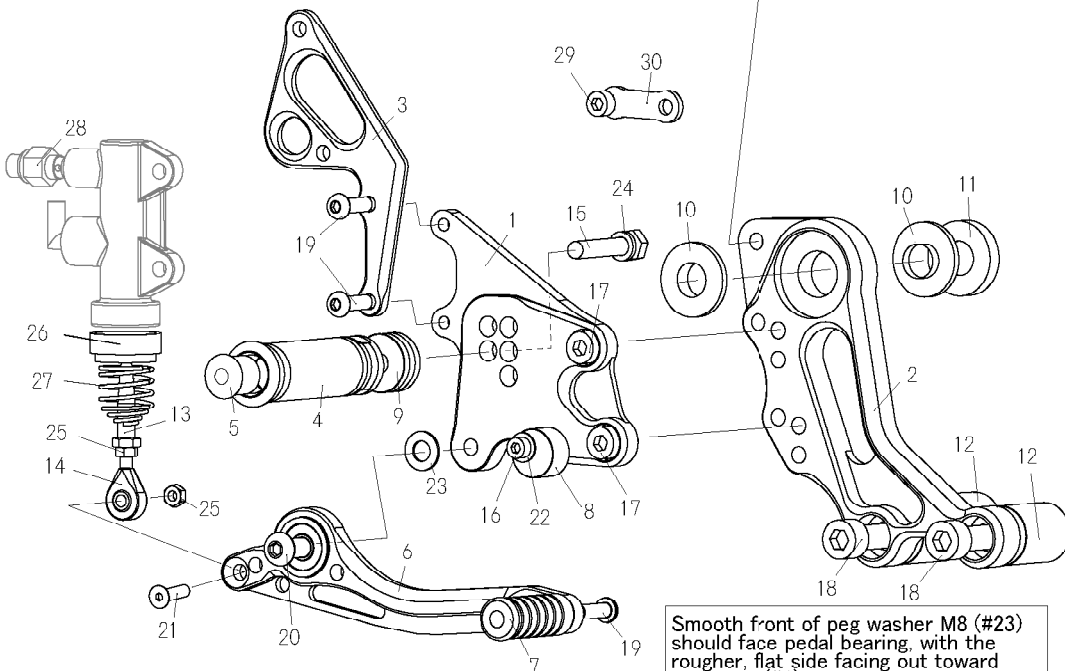

1. STEP PLATE [R]
2. BASE PLATE [R]
3. HEEL GUARD [R] (HG21)
4. FOOT PEG
5. FOOT PEG END CAP
6. BRAKE PEDAL 150-2 (BPD14)
7. PEDAL TIP
8. BRAKE PEDAL STOPPER(BK)
9. FOOT PEG COLLAR 12
10. COLLAR 3.5 (BK) × 2
11. COLLAR 7.5(BK)
12. COLLAR 33(BK) × 2
13. PUSH ROD(BK)
14. MAIN ROD FND M5
15. HEX BOLT M8 × 40mm
16. SOCKET HEAD M5 × 25mm
17. SOCKET HEAD M8 × 15mm × 2
18. SOCKET HEAD M10 × 55mm(P-1.5) × 2
19. BUSHION HEAD M6 × 20mm × 3
20. BUTTON HEAD M8 × 25mm
21. FLAT HEAD M5 × 20mm
22. WASHER M5
23. PEG WASHER M8
24. SPLIT WASHER M8
25. NUT M5
26. RETURN SPRING COLLAR(BK)
27. RETURN SPRING 20
28. BRAKE LIGHT SWITCH P-1.0
29. SOCKET HEAD M6 × 10mm
30. UNIVERSAL BRACKET UB-M625(SV)

Smooth front of peg washer M8 (#23) should face pedal bearing, with the rougher, flat side facing out toward step plate(#1).